



中国电信  
CHINA TELECOM

# Cloud-Native Plinth: A Platform to Support Containerized 5G Core Network

---

Shen Gao, Shuo Quan, Jie Wu

China Telecom Cloud Computing Research Institute, China  
Temple University, USA

# 5GC Architecture

- Service Based Architecture (SBA)
  - Consists of a series of network functions (NFs)
  - Network Function Virtualization (NFV), Virtual Machine & Container
  - Software-Defined Networking (SDN)
- Application Function (AF)
  - User Plane Function (UPF)
  - Policy Control Function (PCF)
  - Access and Mobility Management Function (AMF)
  - NF Repository Function (NRF)
  - Network Exposure Function (NEF)
  - Session Management Function (SMF)
  - Unified Data Management (UDM)
  - Authentication Server Function (AUSF)
  - Network Slice Selection Function (NSSF)

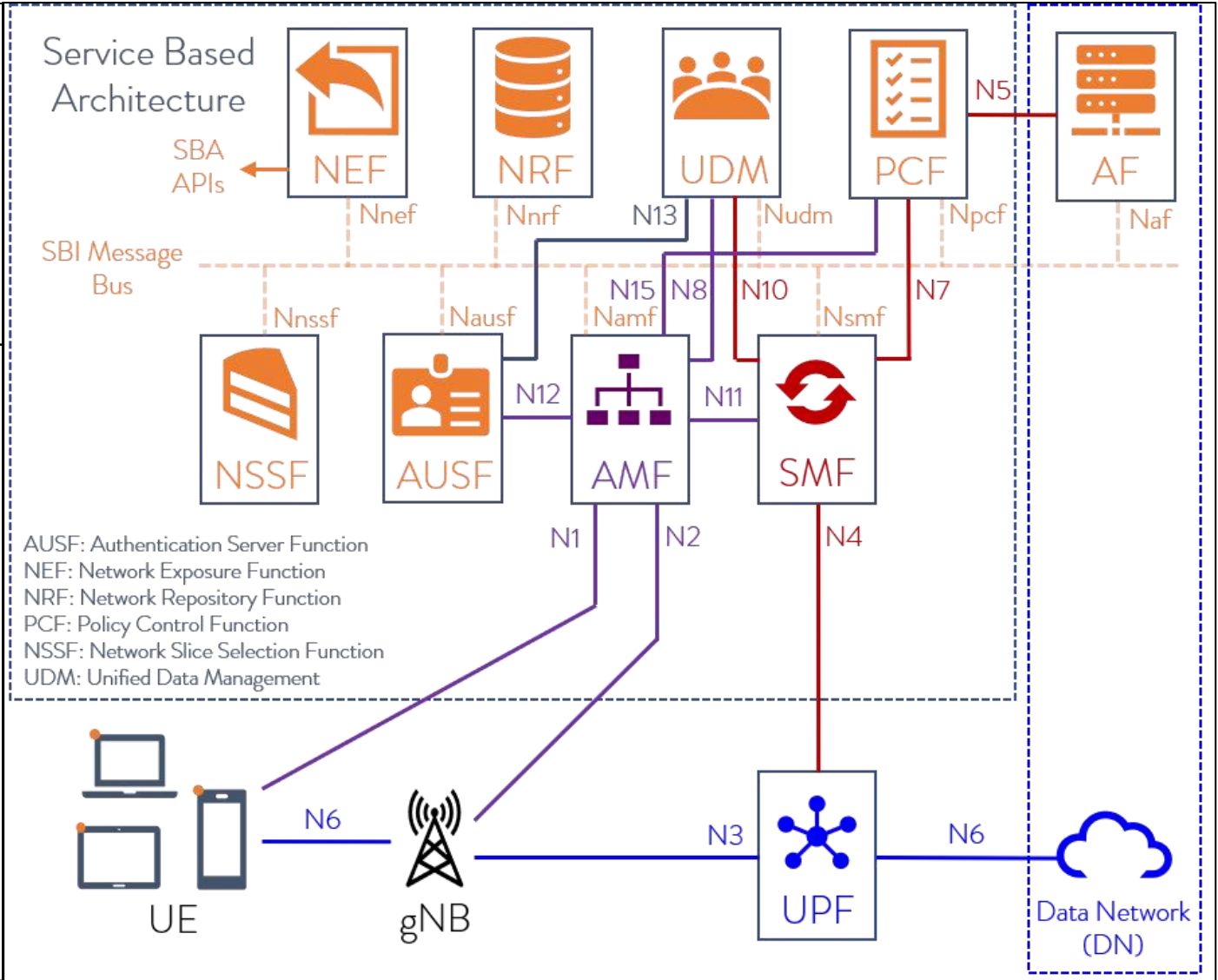

# 5GC containerization evolution

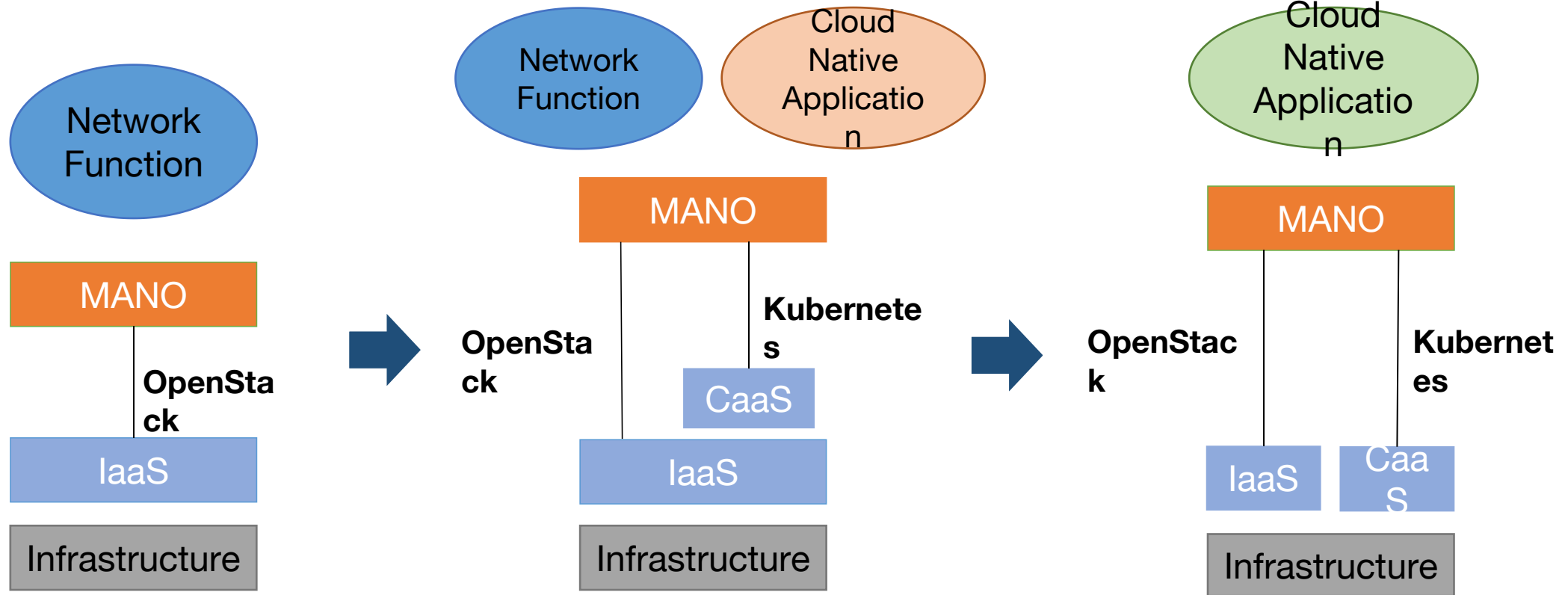

**Virtual machine deployment**

**Container deployment based on virtual machine environment**

**Container deployment**

# 5GC deployment based on Kubernetes

- Multi-cluster node distributed deployment architecture
- Service to achieve load balancing between multiple copies of network functions
- Node communication through OVS

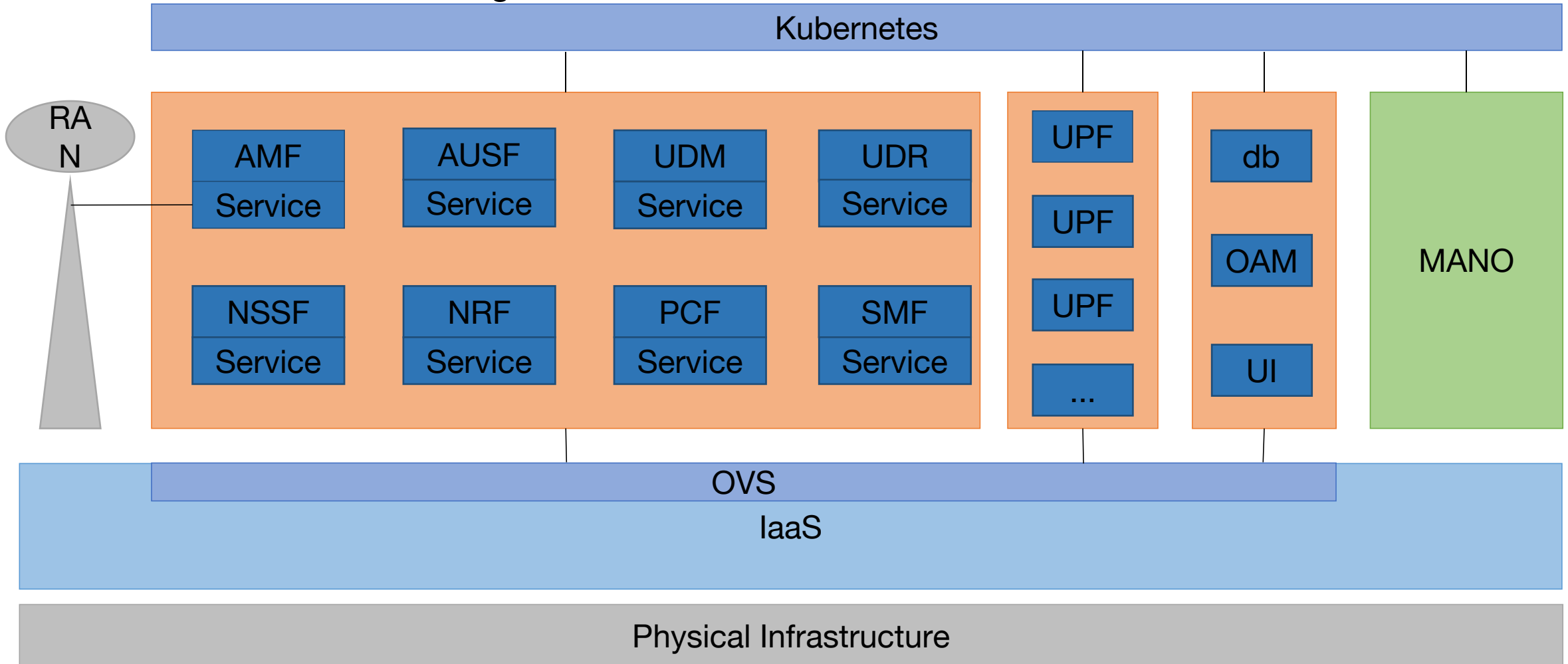

- Scaling capability of Kubernetes are not sufficient to stateful services. If the state data cannot be saved and restored, scaling the network function directly will invalidate the original state of network.
- Kubernetes lacks operation and maintenance functions. Although other cloud-native tools (such as Prometheus) can provide monitoring services, there is no unified operation and maintenance solution specifically for 5GC.
- Kubernetes supports basic storage solutions such as PVC, but cannot provide advanced data backup methods necessary for recovery after system failure.
- 5GC network functions require multiple network planes for communication, but Kubernetes only supports single network plane.

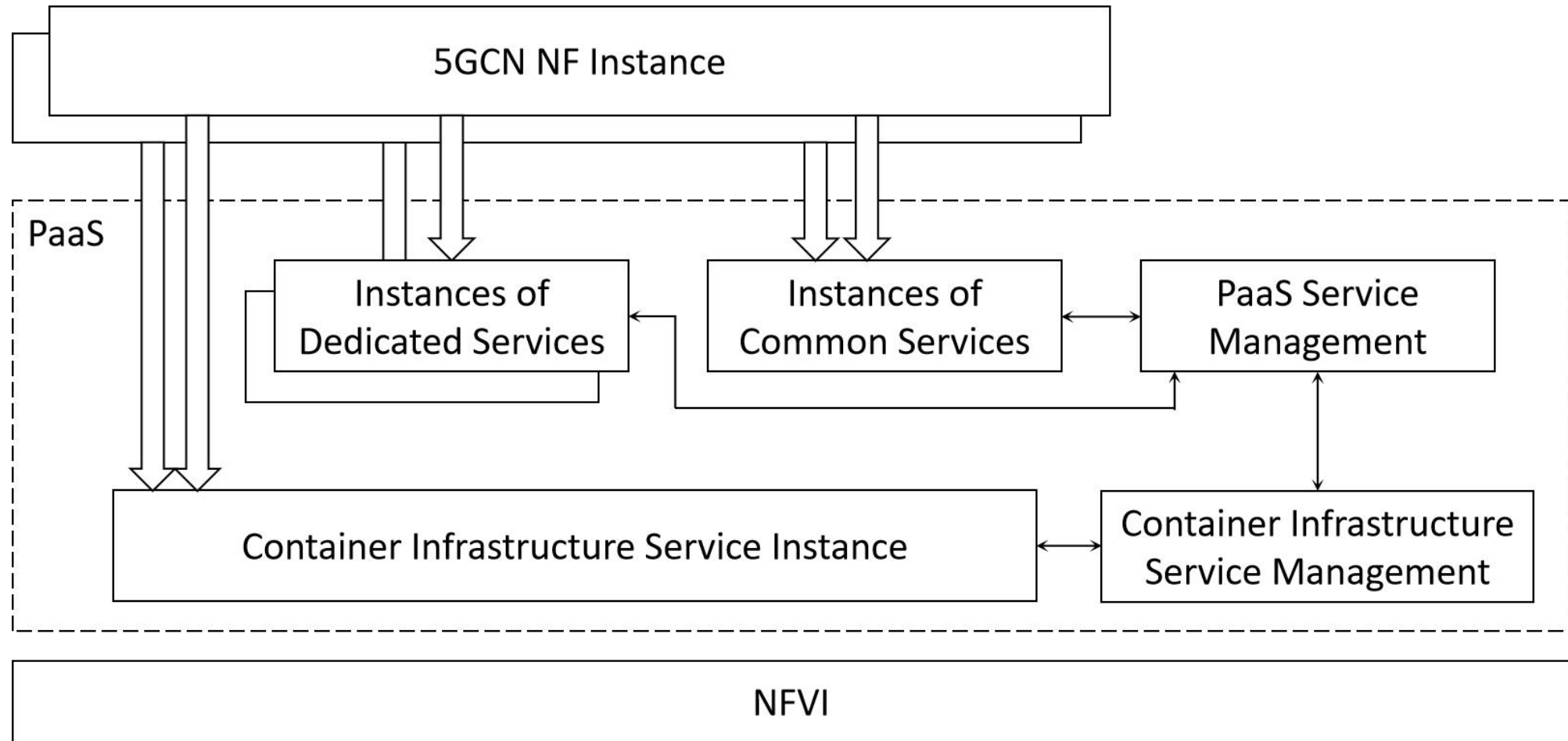

ETSI NFV-IFA 029 “Report on the Enhancements of the NFV architecture towards ‘Cloud-native’ and ‘PaaS’ “

# What kinds of services can be common services of 5GC?



Application Definition ?

Database?

Image Build?

Cloud Native  
Network?

Service  
Proxy?

Automation & Configuration?

Cloud Native  
Storage?

Security & Compliance?

Observability ?

Service  
Mesh?

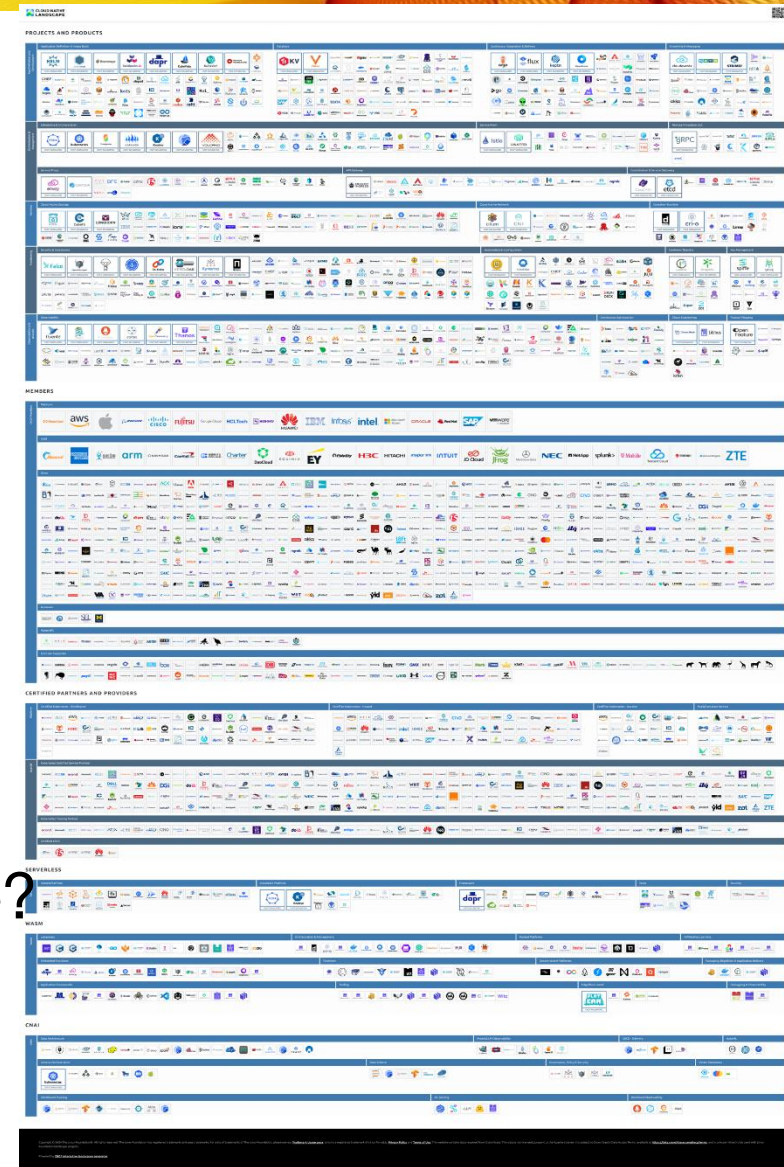

CNCF LandScape (173 projects)

Based on the Kubernetes, this paper introduces novel functions in the PaaS layer from six aspects: network connection, capacity expansion and contraction management, storage management, observability, network acceleration, and security, and builds a cloud-native plinth, aiming to enable 5GC to better use cloud-native capabilities and enhance the performance, availability, and reliability of 5GC.

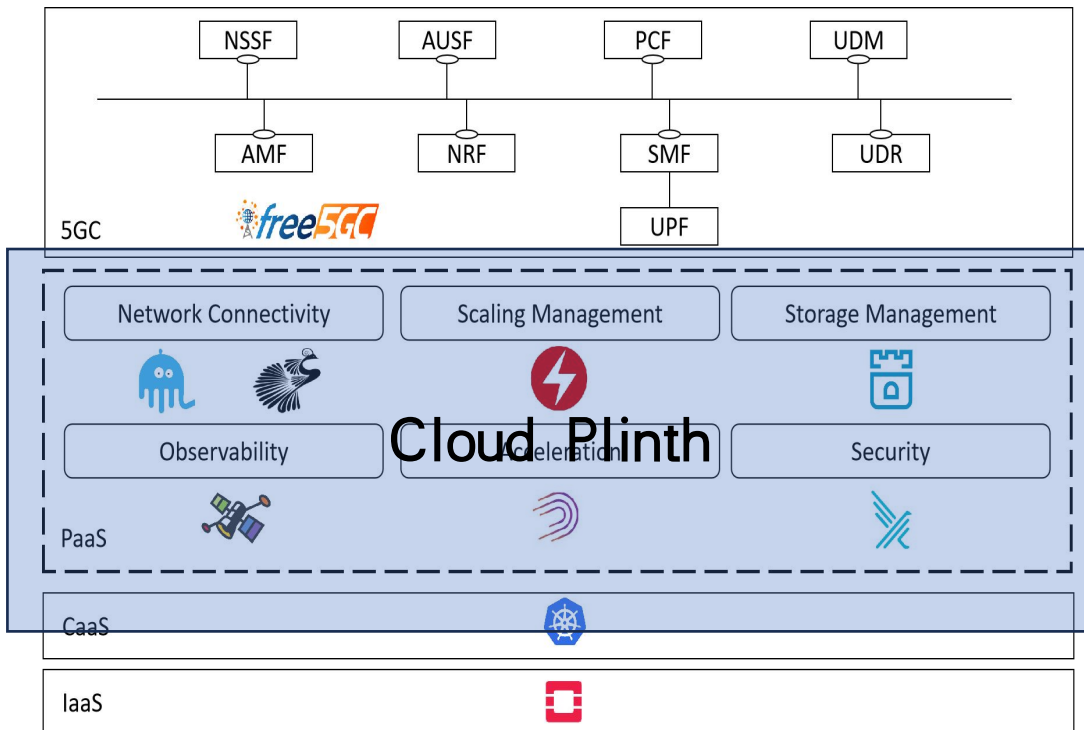

Open Source project	Description
Kube-OVN	Kube-OVN introduces OVN functions of Openstack into Kubernetes which provides more network abilities, such as static IP addresses, to cloud-native clusters.
Multus CNI	Multus CNI enables switching on multiple network interfaces in pods of Kubernetes.
Operator Framework	Operator Framework is a toolkit to manage Kubernetes applications, especially complex stateful applications.
Rook	Rook is a cloud-native storage orchestration for Kubernetes which provides self-managing, self-scaling and self-healing storage services.
Hubble	Hubble is built on top of Cilium and eBPF to enable deep observability.
DPDK	DPDK, designed to run on x86, POWER and ARM processors, is to accelerate package processing workloads.

# Cloud-Native Plinth – Network Connection



- Communication between 5GC network functions relies on specific interfaces.
- Most network functions need to be associated with multiple interfaces and require support from multiple network planes.
- The 5GC network function needs to be registered with the NRF network function and requires a static IP. The network connection function provided by Kubernetes cannot support the static IP function and requires Kube-OVN.

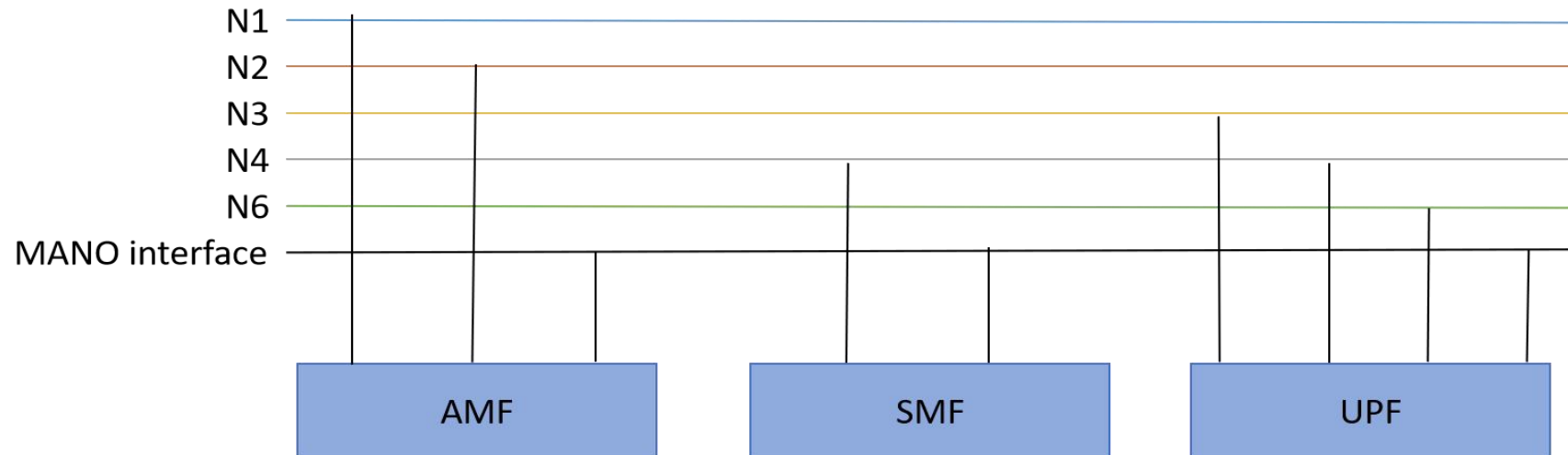

# Cloud-Native Plinth – Scaling Management

The horizontal and vertical expansion functions provided by Kubernetes cannot meet the expansion and contraction management requirements of stateful services. Operator Framework can customize and extend Kubernetes functions, create CRDs in Operator, and define expansion and contraction algorithms and state processing functions.

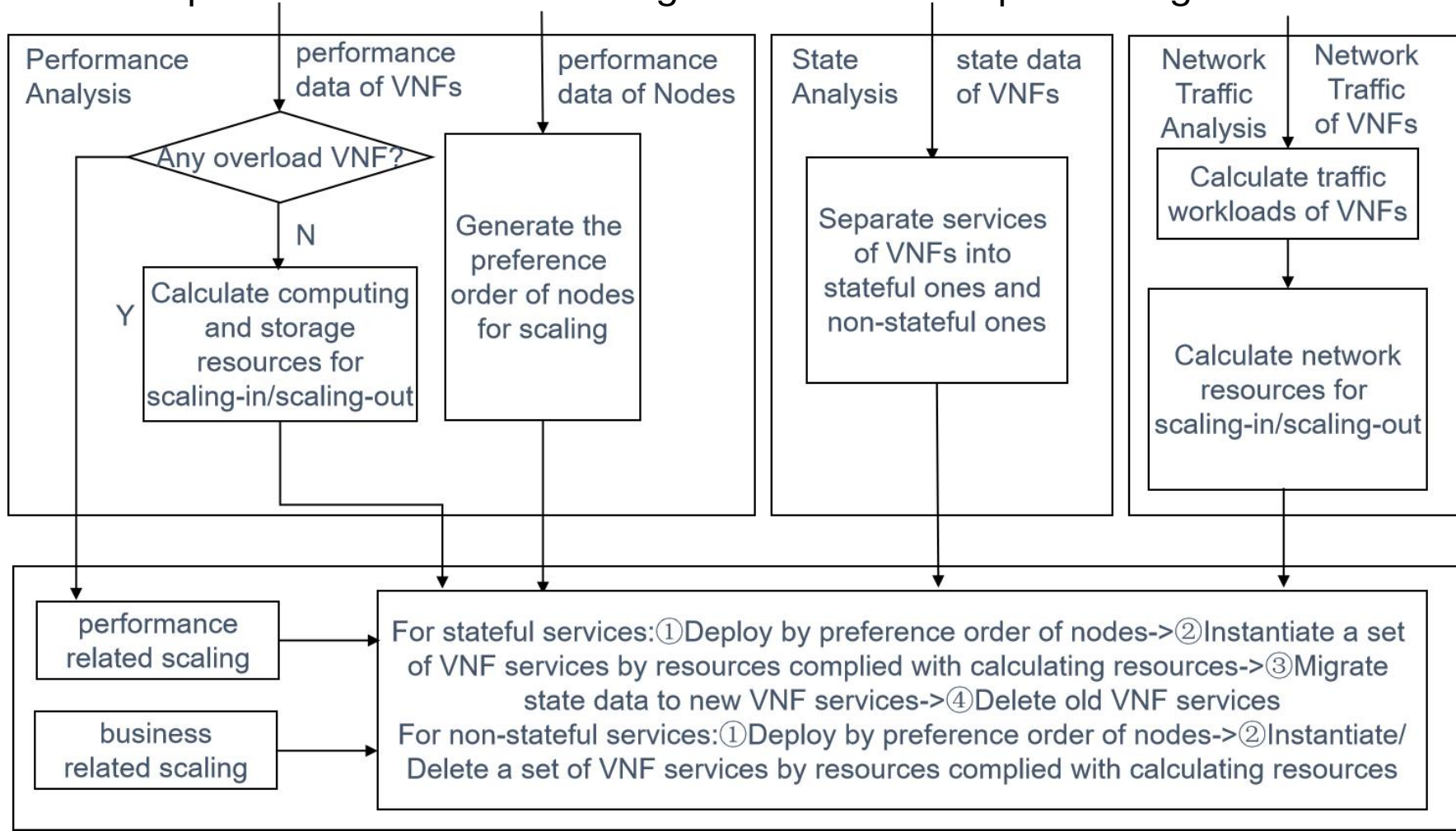

Rook transforms distributed storage software into self-managing, self-scaling and self-healing storage services.

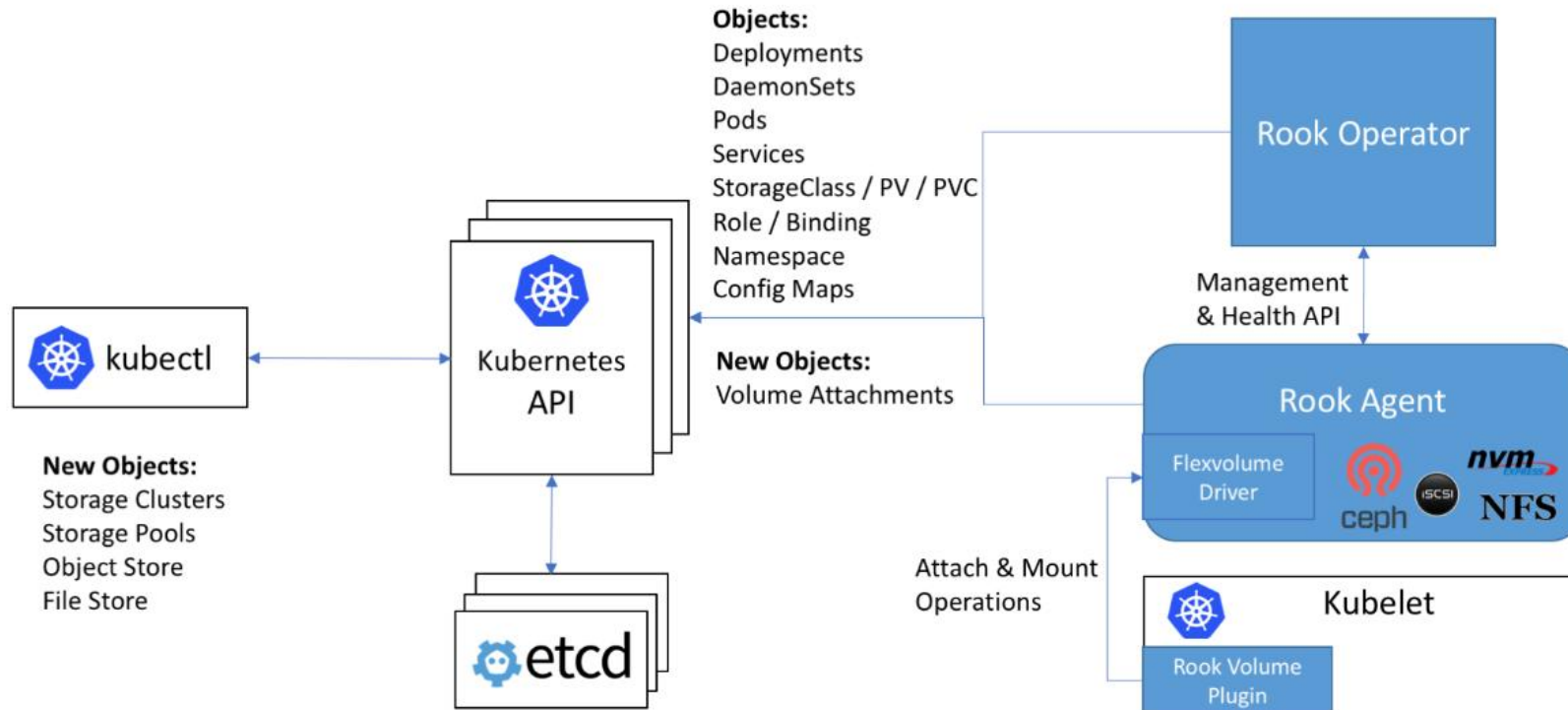

# Cloud-Native Plinth – Network Acceleration

The transmission of network traffic involves multiple steps, including the physical NIC driver, the host kernel network protocol stack, the kernel's virtual switching layer, and the virtual NIC driver.

At the same time, many operations are included, such as system interrupts, memory copying, and virtualization encapsulation.

DPDK speeds up the forwarding of user data and promotes network acceleration by bypassing the operating system's kernel. But DPDK lacks the functionality to handle the TCP/IP protocol. Therefore, the Vector Packet Processing (VPP) platform is used to manage the transmission of user protocol data and leverage its ability to handle the TCP/IP protocol.

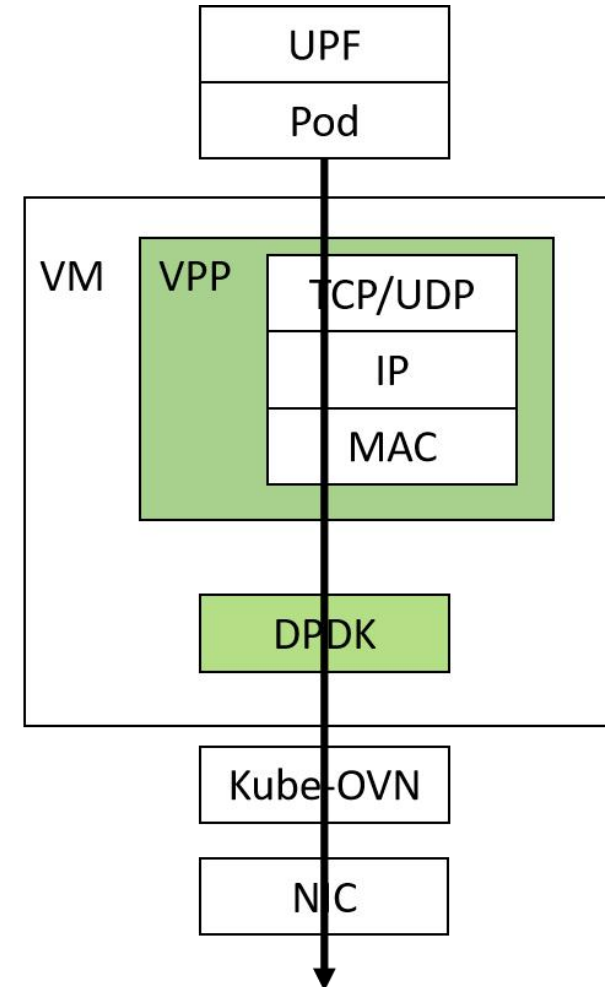

**Falco:** It is a command line display based on rule scanning, which is somewhat similar to tcpdump. It can provide gRPC service for front-end interface connection and collection.

**Rule Engine:** It parses various yaml rules defined in Falco into the rule engine, and is responsible for filtering and triggering events to Falco.

**libsinsp:** It obtains and supplements the underlying events reported from libscap and sends them to Rule Engine for filtering.

**libscap:** This library provides functions similar to libpcap, which is used to set collection control parameters, save files and collect operating system level status.

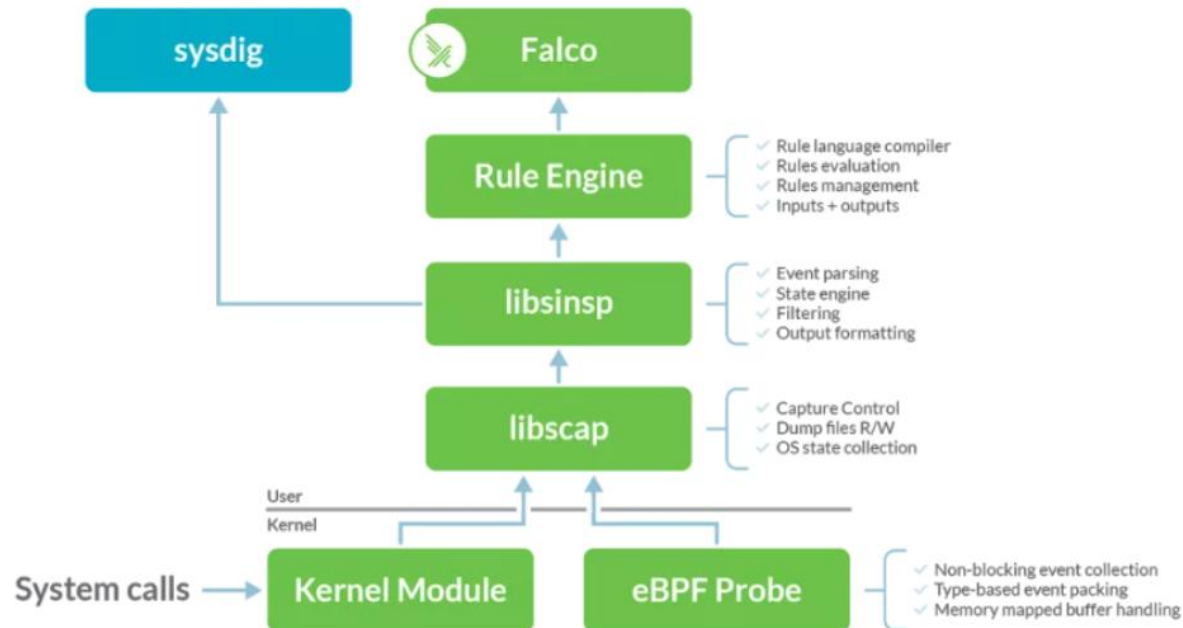

We set up OpenStack on the four-server infrastructure and applied KVM hypervisor for virtualization. 15 VMs are instantiated for the propose of creating Kubernetes cluster.

One server allocated for the deployment of OpenStack management components, and three servers designated for the deployment of Kubernetes Master, among which two are designated for the deployment of 5GC control plane network elements such as AMF, SMF, and PCF, while one is dedicated to deploying the data plane UPF.

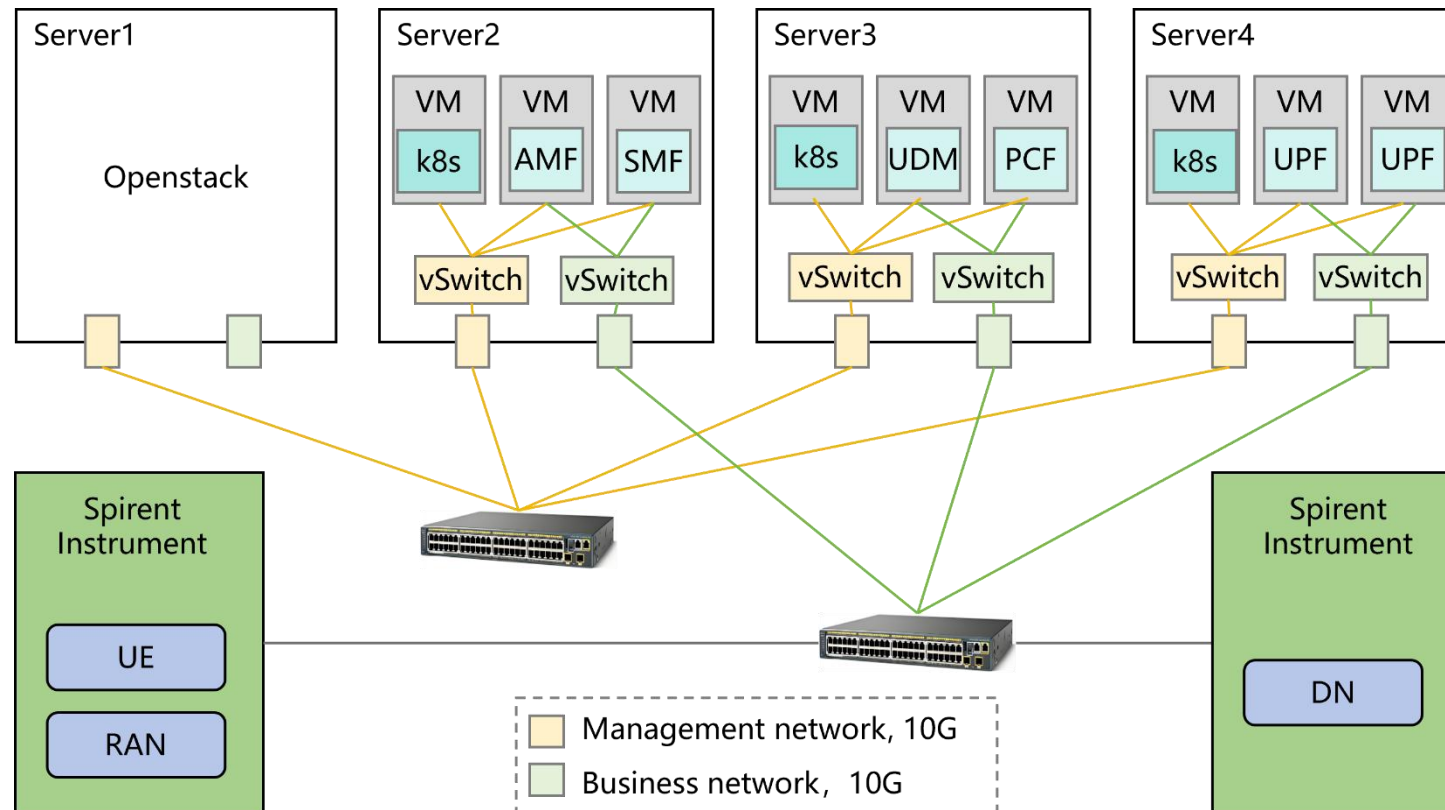

Comparative analysis of network performance under two different configurations: (i) CNP, and (ii) Kubernetes integrated with OpenvSwitch (OVS).

